

# Guidelines for the Customer Provision of Printed Packaging Materials

## Contents:

1. General
2. Requirements for labels (cans and jars)
3. Requirements for packaging inserts
4. Requirements for folding boxes
5. Responsibilities for packaging materials provided

## **General**

### **Delivery Address for the customer provision of printed packaging materials:**

Goerlich Pharma GmbH  
Am Gewerbering 4/6  
83533 Edling  
GERMANY

### **Delivery hours:**

Monday - Thursday: from 08:00 to 16:00  
Friday: from 08:00 to 13:00

### **E-Mail:**

[supply@goerlich-pharma.com](mailto:supply@goerlich-pharma.com) or your account manager

## **Important notes**

Please attach a batch-related certificate of analysis to each provided material.

The acceptance of materials provided by customers requires a clear labelling or identification of the packages and the attached shipping documents. Please note our request of provision number as reference number on all documents.

If the provided materials are not supplied in time, the production will fall behind schedule as well as the delivery date.

Please note that if the packaging materials provided do not meet our requirements, we cannot guarantee that the process will continue on schedule.

In case of any questions, please contact your contact person.

## Requirement for labels (cans and jars)

<b>Requirements:</b>	Self-adhesive labels
<b>Quality:</b>	Polyethylen (PE)-Folie
<b>Glue:</b>	Rafatac (RP37), Company Herma (62x)  Permanent adhesive, but there should be the possibility to take the labels off the first 30 minutes after application (to avoid destruction of container or glass in case the label is not running properly on machine). Glue should also comply with food regulations
<b>Direction of winding:</b>	first word off ext ahead, label outside
<b>Number of labels on rolls:</b>	max. 270mm overall diameter, 1 remaining roll accepted per delivery
<b>Roll core diameter:</b>	exactly 76 mm (obligatory)
<b>Marking:</b>	Space for the imprint of batch number and expiry date of 2x1,5 cm (Width x Height) in total at the bottom edge of the label (it is not necessary to leave this space open – can be printed with lacquer). If the label is very small, we can also stamp batch no. and expiry date vertically on the right-hand edge of the label
<b>Declaration:</b>	<ul style="list-style-type: none"> <li>- Quantities of colours (+ UV lacquer)</li> <li>- Description of colours</li> <li>- Size of label</li> </ul>
<b>Tolerance:</b>	<ul style="list-style-type: none"> <li>- Label height +/- 1mm</li> <li>- Label length + 1mm / - 2mm</li> </ul>
<b>Role-running:</b>	see picture

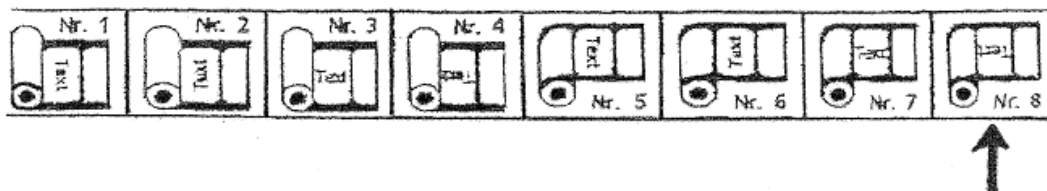

**Surcharges for label provisions:** Please consider the following surcharges:

Required label quantity	surcharges
1.000 labels	25 %
5.000 labels	10 %
10.000 labels	5 %
20.000 labels	4 %
50.000 labels	3 %
100.000 labels	2 %

## Requirement for packaging inserts

### Paper specification for folding the leaflets with our folding machine

- Paper weight (according to DIN EN ISO 536) 40 – 60 g/m<sup>2</sup>  
Single-layer min. 50 g/m<sup>2</sup>, Multi-layer min. 40 g/m<sup>2</sup>
- Thickness 52 – 100 µm
- Paper moisture (according to DIN EN ISO 534) 46 – 58 %, 20°C
- Smoothness (according to BEKK) 25 – 55 s
- Flexural strength 6 – 8 mN
- The fold edge must run 90° to the grain direction of the paper.
- The **paper** must be sealed airtight in foil. Insert a cardboard box, approx. 2 mm thick, the size of the instruction leaflet at the top and bottom for protection.
- The film must be tightly stretched so that the leaflets do not shift.
- **Minimum dimension of the packaging insert: 90 x 120 mm**
- **Maximal dimension of the packaging insert: 210 x 297 mm**
- The length and width tolerance is +/- 0.5 mm.

**Surcharges for leaflet provisions:** Please consider the following surcharges:

Required leaflet quantity	surcharges
1.000 leaflets	5 %
5.000 leaflets	3 %
10.000 leaflets	2 %
20.000 leaflets	1 %
50.000 leaflets	1 %
100.000 leaflets	1 %

## Requirement for folding boxes

**IMPORTANT:** The lateral dust flaps must not exceed 27mm!

A **matt varnish over a full-surface solid colour** usually leads to colour abrasion, as the matt varnish does not seal the surface as well as a standard dispersion varnish. When applying a matt finish, we generally recommend using a matt film as a 'final finish'. This provides a great matt effect. In this case, please make sure that the stamp field is left out accordingly!

### **Batch and best before date space required on folding box:**

Reserved, print-free space for the imprint of batch no. and BBD **on a tuck-in flap**. Please note that **the space for printing the batch no. and BBD must be free of varnish** to ensure good printing.

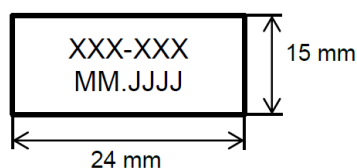

For folding boxes with **flash bottom**, **printing BBD/batch on the bottom is not possible**. The variable data must be printed on a flap.

### **Folding box:**

**A** = the dimension at the base, parallel to the axis of rotation of the dust flaps

**B** = the second dimension on the base area

**H** = the height, the vertical dimension between the two dust flaps

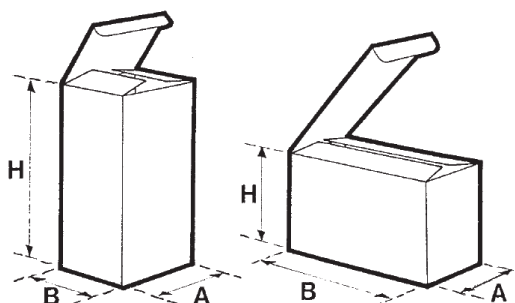

### **Surcharges for box provisions:**

Please consider the following surcharges:

Required boxes' quantity	surcharges
1.000 folding boxes	10 %
5.000 folding boxes	4 %
10.000 folding boxes	2 %
20.000 folding boxes	1,5 %
50.000 folding boxes	1 %
100.000 folding boxes	1 %

# Folding box layout for blister products

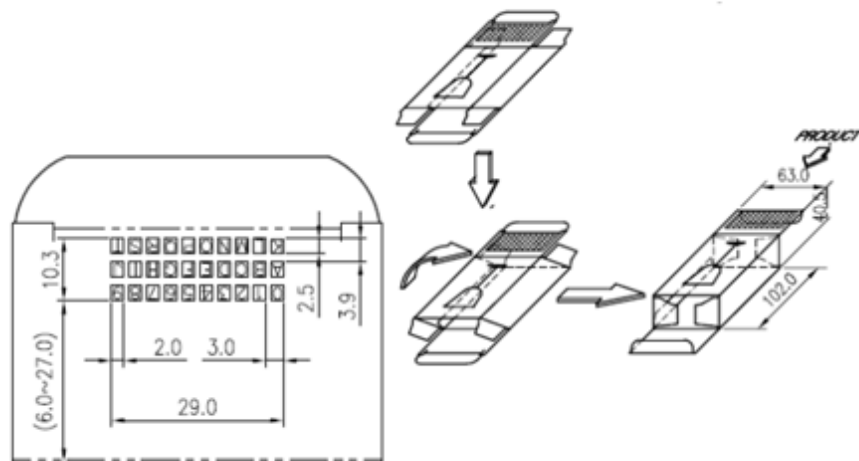
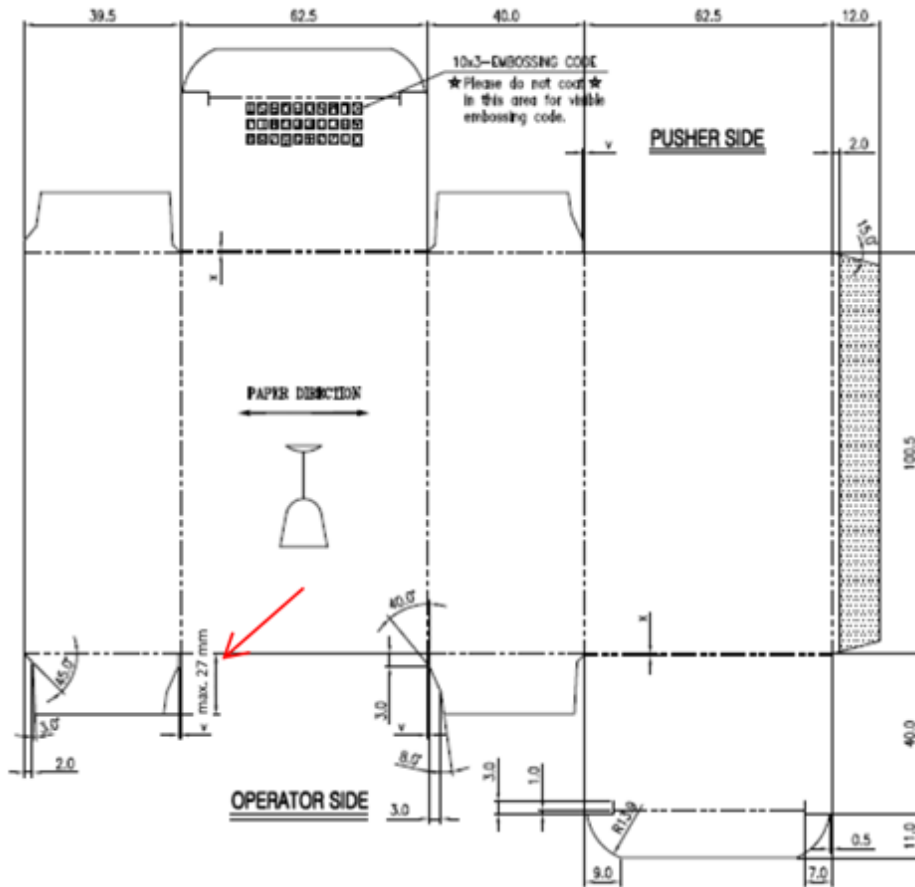

## Information

1. You give us a legally binding order to use the packing materials sent for the corresponding order.
2. We would like to point out that you, as a customer are responsible and liable for all advertising messages. We assume that all texts, images, and further media transmitted to Goerlich Pharma is not subject to the rights of third parties.
3. By agreeing to the use of your materials, you assume all responsibilities for possible typos or misspellings, and at the same time you declare that the phrasing is legally correct. Goerlich Pharma will not check the content of any statements made.

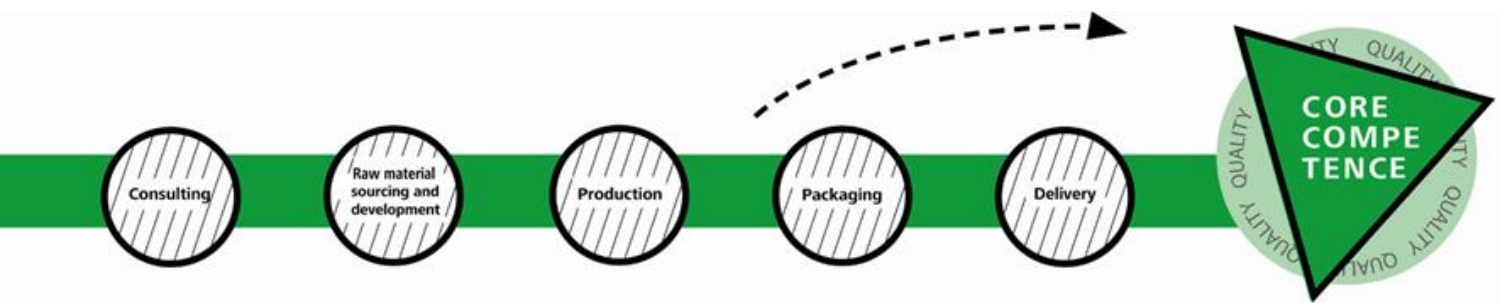

“We communicate openly and transparently at all times. We develop, test, evaluate and go the extra mile for you, because development sometimes is like a marathon run.

The goal is always clearly in sight:

A PERFECT PRODUCT IN PERFECT PACKAGING.”

### How to contact us:

Am Gewerbering 4/6, D-83533 Edling

Tel: +49 (0)8071/-9083-0

Mail: [sales@goerlich-pharma.com](mailto:sales@goerlich-pharma.com)